

ARMARIOS/WARDROBES

ASTRIS

ARMARIOS / WARDROBES

ASTRIS

SOBRE NOSOTROS

ASTRIS ha sido creada para satisfacer las necesidades de los clientes más exigentes. Astris apuesta por la innovación y el diseño como base para lograr productos de alta calidad con una selección de las mejores materias primas y componentes. Así, aseguramos la durabilidad de nuestros productos. Ofrecemos una amplia gama de propuestas con variedad de medidas y distribuciones interiores para adaptarse a cualquier espacio y crear ambientes totalmente personalizados. La profesionalidad demostrada en nuestro trabajo es apoyada por la adición de nuevas técnicas de fabricación, que ayudan a conseguir los mejores resultados posibles en un proceso de creación completamente hecho en España.

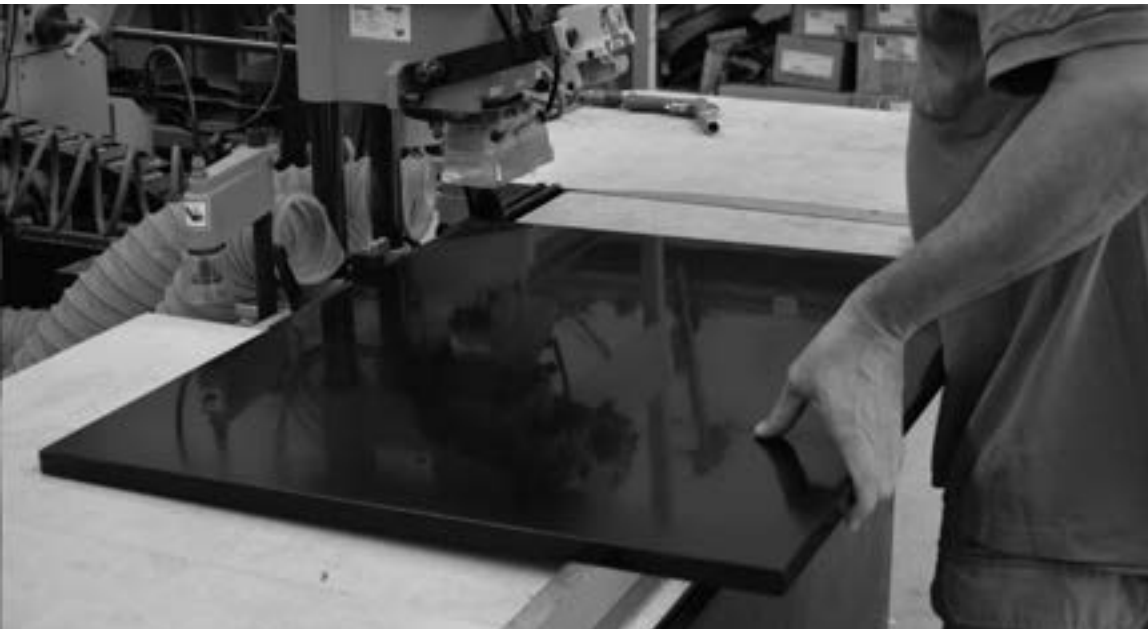

ABOUT US

ASTRIS has been created to satisfy the needs of the most demanding customers. Astris is committed to innovation and design as base to achieve products of high quality with a selection of the best raw materials and components. Thus, we ensure the durability of our products. We offer a wide range of proposals with a huge variety of measures and interior distributions so we get totally personalized and adapted environments. The professionalism we have in our work is supported by the addition of new manufacturing techniques, which helps us to achieve the best results in a process of creating completely made in Spain.



NUESTRA FILOSOFIA

En ASTRIS creemos firmemente en el diseño como una parte fundamental del día a día en nuestras vidas. El diseño, útil y estético, junto a la armonía en la decoración, son un aporte imprescindible a nuestro bienestar. Por ello, cuidamos al máximo los detalles en todos nuestros trabajos mimando cada producto como único. Creamos muebles en los que el equilibrio entre el producto y el diseño se adecua a cada uno de nuestros clientes, amantes del diseño y la decoración. Llevamos años esforzándonos al máximo para diseñar productos cada vez más respetuosos.

OUR PHILOSOPHY

In ASTRIS we believe firmly in the design as a fundamental part of the day to day in our lives. The design, useful and aesthetic, next to the harmony in the decor, are an essential contribution to our welfare. Therefore, we pay special attention to the details in all our work taking care of each product as unique. We create furniture with a balance between the product and the design that fits to each of our clients, lovers of design and decoration. We have spent years trying our best to design products increasingly environmentally friendly.



ÍNDICE/ INDEX

01
/COMPOSICIÓN/



02
/COMPOSICIÓN/



03
/COMPOSICIÓN/



04
/COMPOSICIÓN/



05
/COMPOSICIÓN/



06

/COMPOSICIÓN/



07

/COMPOSICIÓN/



08

/COMPOSICIÓN/



09

/COMPOSICIÓN/



10

/COMPOSICIÓN/



11

/COMPOSICIÓN/



01

/COMPOSICIÓN/

Ambiente sobrio y elegante formado por un armario de tres puertas coplanares en dos acabados. La combinación del color liso con la madera le da un toque de distinción a este espacio en el que la veta de la madera aporta la calidez.

Sober and elegant atmosphere formed by a wardrobe of three coplanar doors in two finishes. The combination of plain color with the wood gives it a touch of distinction to this space in which the grain of the wood provides the warmth.



*Armario tres puertas coplanares con dos acabados.
Madera de wengué combinado gris antracita.
Puerta Tipo 2
Wardrobe with three coplanar doors with two finishes.
Wengue wood combined with grey anthracite.
Door Type 2*









Tecnología y detalle se unen en este armario con decoración mecanizada. La pureza de sus ondas transmiten sensación de equilibrio y continuidad. Puede adaptarse a cualquier tipo de ambiente gracias a la simplicidad y limpieza no solo de su forma sino también de sus acabados.

Technology and detail are joined in this wardrobe with mecanized decoration. The purity of their waves transmit a balance and continuity sensation. It can be adapted to any type of environment thanks to the simplicity and cleanliness not only from its form but also of its finishes.

02
/COMPOSICIÓN/

*Armario seis puertas en dos acabados lacados. Apertura corredera color blanco con decoración mecanizada Sea. Tirador tipo perfil.
Puerta Tipo 3
Wardrobe with six sliding doors in two laquered finishes.
White colour combined with Sea relief decoration. Profile handle.
Door Type 3*

ASTRIS/ARMARIOS

La sensación de amplitud en el espacio se ve aumentada con el uso de espejos en este armario. Además, el uso de tiradores mecanizados en las puertas crean un mueble de gran limpieza visual y sencillez.

The feeling of spaciousness in the space is enhanced with the use of mirrors in this wardrobe. In addition, the use of mechanized handles on the doors create a furniture of great visual cleanliness and simplicity.



03

/COMPOSICIÓN/

Armario seis puertas correderas en un acabado. Combinación de puertas color negro brillo con puertas en acabado espejo. Tirador mecanizado.

Puerta Tipo 1

Wardrobe with six sliding doors in one finish. Combination of gloss black with mirror doors. Mechanized handle.

Door Type 1

ASTRIS / ARMARIOS









Los armarios salen del dormitorio para ocupar cualquier espacio del hogar. En este caso, lo encontramos en el salón, donde se usa para ocultar el televisor y otros objetos y conseguir un espacio armónico visualmente. Las diferentes combinaciones posibles ofrecen armarios personalizados según distintos gustos.

The wardrobes come out of the bedroom to fill any space of the home. In this case, we can find it in the living room, where it is used to hide the TV and other objects and achieve a harmonious space. The different possible combinations offer custom closets according to different tastes.

04
/COMPOSICIÓN/

Armario seis puertas correderas en un acabado. Combinación de madera y kashmir. Tirador tipo marco.

Puerta Tipo 1

Wardrobe with six sliding doors in one finish. Combination of wood and kashmir. Frame handle.

Door Type 1

ASTRIS / ARMARIOS

05

/COMPOSICIÓN/

El relieve de la tecnología láser nos proporciona una decoración distinta. Con la decoración de láser Spring obtenemos un armario con un toque sutil de distinción y originalidad. Además, con el dibujo conseguimos una sensación de continuidad y equilibrio en nuestro espacio.

The relief of the laser technology provides us with a different decoration. With the decoration of laser Spring we got a wardrobe with a delicate touch of distinction and originality. In addition, with the drawing we got a sense of continuity and balance in our space.



*Armario de puertas correderas en dos acabados.
Combinación de blanco brillo con decoración Láser Spring.
Puerta Tipo3
Sliding doors wardrobe in two finishes.
Combination between gloss white and laser Spring decoration.
Door Type 3*

ASTRIS / ARMARIOS









La creación de este ambiente con inspiración vintage se consigue gracias a la decoración de las puertas con imágenes que evocan al pasado y a la nostalgia. Con el uso de la técnica de impresión digital, se incorporan nuevas tecnologías al diseño de un mueble moderno y funcional.

The creation of this atmosphere of vintage inspiration is achieved thanks to the decoration of the doors with images that evoke the past and the nostalgia. With the use of the digital printing technique, we incorporate new technologies to the design of a modern and functional furniture.

Armario nueve puertas abatibles. Combinación de acabado lacado brillo con técnica de impresión digital Antic color.

Puerta Tipo 3

Nine swinging doors wardrobe. Combination between gloss lacqued finish and digital impression technique Antic colour.

Door Type 3

07

/COMPOSICIÓN/

Colorido armario de aspecto divertido y juvenil. La impresión digital permite darle un toque de color a nuestro hogar además de un efecto de relieve óptico que se consigue gracias al diseño de líneas geométricas.

Colorful wardrobe with fun and youthful appearance. Digital printing allows us to give a touch of color to our home in addition to an optical effect that is highlighted to get thanks to the design of geometric lines.



Armario diez puertas abatibles. Dos acabados, combinación de blanco brillo con impresión digital Cube. Tirador modelo 0567.

Puerta Tipo 3

Wardrobe with ten swinging doors. Two finishes, combination of gloss white and digital impression Cube. Handle model 0567

Door Type 3

ASTRIS / ARMARIOS







08

/COMPOSICIÓN/



Los colores lisos y vibrantes se combinan con la madera tradicional en este armario de dormitorio. Un resultado original y llamativo que le da vida y luz al ambiente.

The plain and vibrant colors are combined with the traditional wood in this bedroom wardrobe. A striking and original result that gives it life and light to the environment.

Armario cuatro puertas en dos acabados. Apertura corredera con combinación en madera y colores lisos.

Puerta Tipo 6

Wardrobe with four sliding doors in two finishes. Combination between wood and plain colours.

Door Type 6

ASTRIS/ARMARIOS

En este vestidor todo el espacio es aprovechado para hacerlo funcional. Modularidad, diseño y elegancia con la máxima adaptabilidad para conseguir un ambiente exclusivo.

In this walk-in closet the whole space is used to make it functional. Modularity, design and elegance with the maximum flexibility to achieve a unique space.



09
/COMPOSICIÓN/

ASTRIS/ARMARIOS





10

/COMPOSICIÓN/



Vestidor funcional con módulos pensados para cada tipo de prenda y también para los complementos. Con esta solución se aprovecha al máximo el espacio para un almacenaje impecable. Cada prenda y cada objeto tiene su sitio en este vestidor.

Walk-in closet with functional modules designed for each type of garment and also for complements. With this solution we take profit from the space and we make a perfect storage. Every garment and every object has its site in this dressing room.

ASTRIS/ARMARIOS

11

/COMPOSICIÓN/

La combinación de colores en este vestidor le da un aspecto alegre y luminoso. Los diferentes módulos y complementos ofrecen posibilidades infinitas de combinación.

The combination of colors in this dressing room looks bright and cheerful. The different modules and plug-ins offer infinite possibilities of combination.





TECHNICAL CATALOGUE
CATÁLOGO TÉCNICO

ÍNDICE

02 02.1 SISTEMA DE APERTURA
02.2 COMBINACIONES
*/PUERTAS/
P.12*

10 10.1 ABATIBLES
10.2 CORREDEDRAS
10.3 COPLANARES
10.4 AUTOPORTANTES
10.5 ADICIONALES
10.6 CAJONERAS
10.7 GAVETAS
*/MODULACIÓN/
P.22*

01 01.1 ACABADOS EXTERIORES
01.2 ACABADOS INTERIORES
*/ACABADOS/
P.02*

03 03.1 COMPATIBILIDAD
02.2 MODELOS
*/TIRADORES/
P.16*

11
*/ACCESORIOS/
P.40*

INDEX

02 02.1 OPENING SYSTEM
02.2 COMBINATIONS
/DOORS/

04 04.1 SWINGING DOORS
04.2 SLIDING DOORS
04.3 COPLANAR DOORS
04.4 SELF SUPPORTING
04.5 ADDITIONALS
04.6 DRAWERS
04.7 BIG DRAWERS
/MODULATION/

01 01.1 EXTERIOR FINISHES
01.2 INTERIOR FINISHES
/FINISHES/

03 03.1 COMPATIBILITY
02.2 MODELS
/HANDLES/

05
/ACCESORIES/

ACABADOS / FINISHES

01.1 EXTERIORES/EXTERIORS *(P.03)*

LAMINADO / LAMINATED

ESTRATIFICADO / STRATIFY

LACADO / LACQUED

RECHAPADO NATURAL / NATURAL VENEERED

LACADO DIGITAL / DIGITAL LACQUED

LACADO RELIEVE / RELIEF LACQUED

LÁSER / LASER

CRISTAL / CRYSTAL

02.2 INTERIORES/INTERIORS *(P.11)*

ACABADOS EXTERIORES / EXTERIOR FINISHES

LAMINADO / LAMINATED

GRUPO / GROUP 01

GRUPO 01. LAMINADO MATE / MATTE LAMINATED



GRUPO 01. LAMINADO VETA / GRAIN LAMINATED



GRUPO 04. ESTRATIFICADO BRILLO / GLOSS STRATIFY



GRUPO 04. ESTRATIFICADO MADERA BRILLO / GLOSS WOOD STRATIFY



ACABADOS EXTERIORES / EXTERIOR FINISHES

LACADO / LACQUED

GRUPO / GROUP 05

GRUPO 08. LACA MATE / MATTE LACQUED



GRUPO 08. LACA BRILLO / GLOSS LACQUED



GRUPO 08. RECHAPADO NATURAL / NATURAL VENEERED



NOGAL NATURAL
Cod: 800



NOGAL ANTICUARIO
Cod: 801



HAYA NATURAL
Cod: 802



HAYA MARRÓN
Cod: 803



HAYA GRIS
Cod: 804



CEREZO NATURAL
Cod: 805



CEREZO NAJERA
Cod: 806



CEREZO ANTICUARIO
Cod: 807



MUKALI INGLES
Cod: 808



MUKALI AVE-ULT
Cod: 809



MUKALI GRIS
Cod: 810



ROBLE ECOLÓGICO
Cod: 811



ROBLE MARRÓN
Cod: 812



ROBLE TERRA
Cod: 813



ROBLE WENGUÉ
Cod: 814



ROBLE INGLES
Cod: 815



ROBLE GRIS
Cod: 816



ROBLE NEGRO
Cod: 817



CEDRO WENGUÉ
Cod: 818



FRESNO BLANCO
Cod: 819



FRESNO TERRA
Cod: 820



FRESNO AVE-ULT
Cod: 821



ABEDUL
Cod: 822



ROBLE NATURAL
Cod: 823



MAPLE NATURAL
Cod: 824



FRESNO NATURAL
Cod: 825

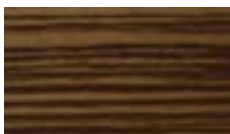

CEBRANO
Cod: 827

GRUPO 09. IMPRESIÓN DIGITAL / DIGITAL IMPRESSION



CÍRCULOS
Cod: CUS00



ONDAS
Cod: CUS01



LÍNEAS
Cod: CUS02



ANTIC COLOR
Cod: CUS03

GRUPO 09. CUBE



AZUL
Cod: GCB02



ROJO
Cod: GCB03



MORADO
Cod: GCB0P



GRIS
Cod: GCB06



VERDE
Cod: GCB01



CHOCOLATE
Cod: GCB05

GRUPO 09. WAVES



AZUL
Cod: GWV02



ROJO
Cod: GWV03



MORADO
Cod: GWV0P



GRIS
Cod: GWV06



VERDE
Cod: GWV01



CHOCOLATE
Cod: GWV05

EXTERIOR FINISHES / ACABADOS EXTERIORES

GRUPO / GROUP 10

RELIEF + LACQUED / RELIEVE + LACADO

GRUPO 10. SEA



BLANCO
Cod:SEA00



GRIS
Cod:SEA08



NEGRO
Cod:SEA04

GRUPO 10. GAEL



BLANCO
Cod:GAE00

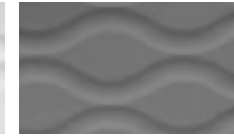

GRIS
Cod:GAE08

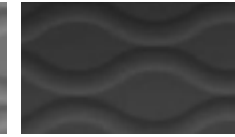

NEGRO
Cod:GAE04

GRUPO 10. FÁBULA



BLANCO
Cod:FAB00



GRIS
Cod:FAB08



NEGRO
Cod:FAB04

GRUPO 10. INTENSE



BLANCO
Cod:INT00



GRIS
Cod:INT08



NEGRO
Cod:INT04

EXTERIOR FINISHES / ACABADOS EXTERIORES

GRUPO / GROUP 10

LASER / LÁSER

GRUPO 10. ALMA



BLANCO
Cod:ALM00



GRIS
Cod:ALM06



NEGRO
Cod:ALM04

GRUPO 10. LOTTO



BLANCO
Cod:LOT00



GRIS
Cod:LOT06



NEGRO
Cod:LOT04

GRUPO 10. SPRING



BLANCO
Cod:SPR00



GRIS
Cod:SPR08



NEGRO
Cod:SPR04

GRUPO 10. MARE



BLANCO
Cod:MAR00



GRIS
Cod:MAR08



NEGRO
Cod:MAR04

ACABADOS EXTERIORES / EXTERIOR FINISHES

CRISTAL / CRYSTAL

GRUPO / GROUP 12

GRUPO 12. CRISTAL / CRYSTAL



ACABADOS INTERIORES / INTERIOR FINISHES



BLANCO SARELA
COD:IBLN

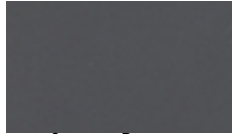

GRIS BIZOT
COD:IGRS



TEXTIL CANCÚN
COD:ITEX



WENGUÉ
COD:IWNG



ZEBRANO ARENA
COD:IZBR

PUERTAS / DOORS

TIPOLOGÍA DE PUERTAS / DOORS TYPES

02.1 SISTEMA DE APERTURA / OPENING SYSTEM *(P.13)*

ABATIBLES / SWINGING
CORREDERAS / SLIDING
COPLANARES / COPLANAR
AUTOPORTANTES / SELF SUPPORTING

02.2 ESTÉTICA / ESTHETIC *(P.14)*

TIPOLOGÍA / TYPE 1
TIPOLOGÍA / TYPE 2
TIPOLOGÍA / TYPE 3
TIPOLOGÍA / TYPE 6

TIPOLOGÍA DE PUERTAS / DOOR TYPES

SISTEMA DE APERTURA / OPENING SYSTEM



TIPO 1. PUERTAS ABATIBLES
SWINGING DOORS

Sistema de puertas abatibles. Disponibles en módulos de 1 puerta, de 2 puertas o en módulos rinconeros. Posibilidad de distintas anchuras y alturas.

Swinging doors system. Available in units of 1 door, 2 doors or corner units. Possibility of different widths and heights.



TIPO 2. PUERTAS CORREDERAS
SLIDING DOORS

Sistema de puertas correderas. Disponibles en módulos de 2 o 3 puertas. Posibilidad de distintas anchuras y alturas.

Sliding doors system. Available in units of 2 doors or 3 doors. Possibility of different widths and heights.



TIPO 3. PUERTAS COPLANARES
COPLANAR DOORS

Sistema de puertas coplanares. Disponibles sólo en módulos de 2 puertas. Posibilidad de distintas anchuras y alturas.

Coplanar doors system. Available only in 2 door units. Possibility of different widths and heights.



TIPO 4. AUTOPORTANTES
SELF SUPPORTING

Sistema de autoportantes. Para vestidores abiertos. Posibilidad de distintas anchuras y alturas.

Self supporting system. For opened walk-in closet. Possibility of different widths and heights.

DOOR TYPES / TIPOLOGÍA DE PUERTAS
EXTERIOR ESTHETIC / ESTÉTICA EXTERIOR



/TIPO 1/
/TYPE 1/

1 ACABADO / FINISH



/TIPO 2/
/TYPE 2/

2 ACABADOS / FINISHES



/TIPO 3/
/TYPE 3/

3 ACABADOS / FINISHES



/TIPO 6/
/TYPE 6/

6 ACABADOS / FINISHES

* LA DISTRIBUCIÓN DE LOS ACABADOS EN LA PUERTA PUEDE SER
PERSONALIZADA AL GUSTO DEL CONSUMIDOR
THE FINISHES DISTRIBUTION IN THE DOOR COULD BE PERSONALIZED
ACCORDING TO THE CONSUMERS' TASTE
CATÁLOGO TÉCNICO/TECHNICAL CATALOGUE 15

TIRADORES / HANDLES

03.1 COMPATIBILIDAD TIRADOR-PUERTA /
HANDLE-DOOR COMPATIBILITY (P.17)

03.2 MODELOS / MODELS (P.18)

TIRADORES / HANDLES
MECANIZADOS / MECHANIZED
INCORPORADOS / INCORPORATED

TIRADORES / HANDLES

COMPATIBILIDAD TIRADOR- PUERTA / DOOR-HANDLE COMPATIBILITY

TABLA DE COMPATIBILIDADES / COMPATIBILITY TABLE

	NEST 105	BINGO 053	ANGLE 077	DECÔ/TOKIO/ EVOLUTION	PERFIL
LAMINADO	•	•	•		•
ESTRATIFICADO	•	•	•		•
LACADO / MADERA	•	•	•	•	•
DIGITAL LACADO	•	•	•		•
LÁSER	•	•	•		•
LACADO RELIEVE					•
CRISTAL					•

NEST 105

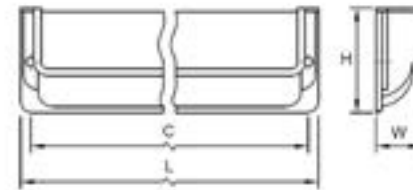

ACABADO	CÓDIGO
Color mate negro	05
Brillante cromado	07
Color mate negro + aluminio	05 + 08
Brillante cromado + aluminio	07 + 08
Aluminio mate	08
C - H	H
205 mm - 215 mm	12,5 mm - 48 mm

DINO 053

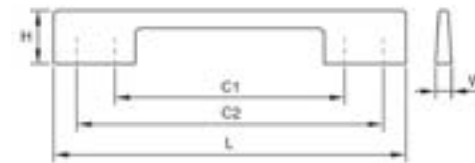

ACABADO	CÓDIGO
Color mate negro	05
Brillante cromado	07
Aluminio mate	08
Aluminio mate negro	08
C1 - C2 - H	H
288 mm - 320 mm - 345 mm	7 mm - 22 mm

ANGLE 077

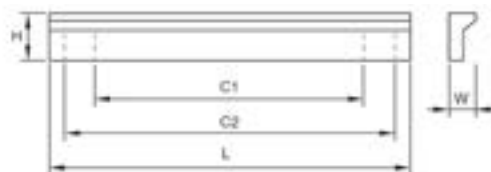

ACABADO	CÓDIGO
Color gris 10	15
Acabado gris	20
Acabado negro	30
Acabado negro	40
Acabado negro	5

C1	C2	-	H	H
120 mm	100 mm	200 mm	17 mm	19.5 mm

WAVE 0119

TIRADOR DE LAS CAJONERAS /
HANDLE FOR THE DRAWERS

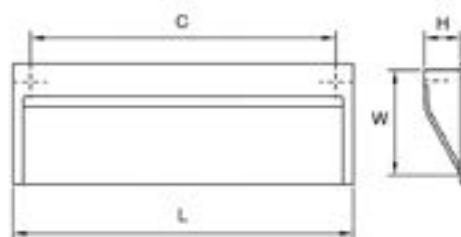

ACABADO	CÓDIGO
Color gris 10	15
Acabado negro	20

C	-	H	H
100 mm	120 mm	40 mm	13.5 mm

DECÓ

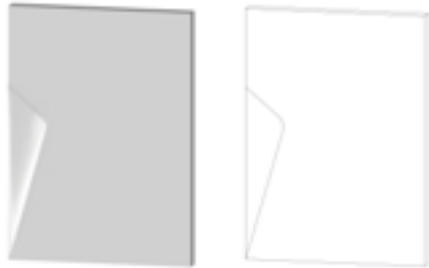

EVOLUTION



TOKIO

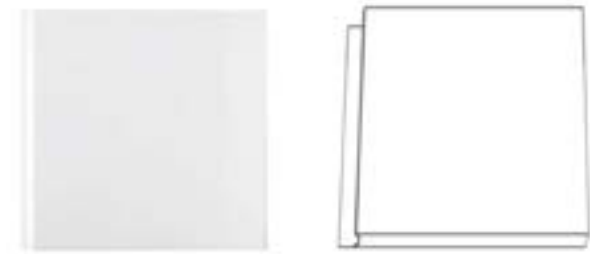

PERFIL / PROFILE



MÓDULOS / UNITS

ABATIBLES / SWINGING (P.23)

CORREDERAS / SLIDING (P.24)

COPLANARES / COPLANAR (P.24)

AUTOPORTANTES / SELF SUPPORTING (P.25)

PERFILERÍA / PROFILES

SOPORTE PORTAESTANTES / SHELVES SUPPORT

ELEMENTOS ADICIONALES / ADDITIONAL ELEMENTS (P.26)

LATERALES / LATERALS

ESTANTES / SHELVES

ZÓCALO / BASEBOARD

REMATE A TECHO / CEILING ENDING

CAJONERAS / DRAWERS (P.29)

SIMPLES / SIMPLE

DOBLES / DOUBLE

GAVETAS / BIG DRAWERS (P.35)

SIMPLES / SIMPLE

DOBLES / DOUBLE

MÓDULOS / UNITS

ABATIBLES / SWINGING

AAXX (Z/W)

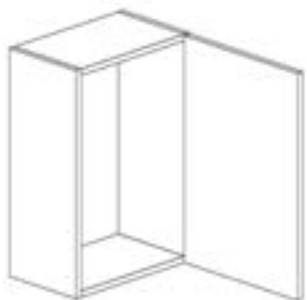

MÓDULO CON PUERTA ABATIBLE

Formado por:
Casco (superior, inferior y trasero)
Costados
1 Puerta

UNIT WITH SWINGING DOOR

Formed by:
frame (upper, lower y back)
sides
1 door

ANCHURA	CÓDIGO	ALTURA	CÓDIGO
30 - 39 CM	001	HASTA 240 CM	Z
40 - 49 CM	002	DL 241 A 270 CM	W
50 - 60 CM	003		

ABXX (Z/W)

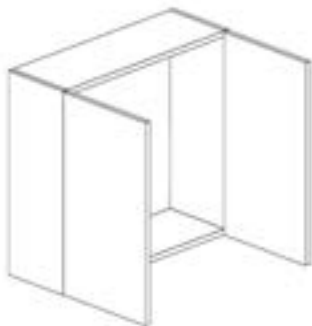

MÓDULO CON PUERTA ABATIBLE

Formado por:
Casco (superior, inferior y trasero)
Costados
2 Puertas

UNIT WITH SWINGING DOOR

Formed by:
frame (upper, lower y back)
sides
2 doors

ANCHURA	CÓDIGO	ALTURA	CÓDIGO
60 - 69 CM	004	HASTA 240 CM	Z
70 - 79 CM	005	DL 241 A 270 CM	W
80 - 89 CM	006		
90 - 99 CM	007		
100 - 109 CM	008		
110 - 120 CM	009		

ACXX (Z/W)

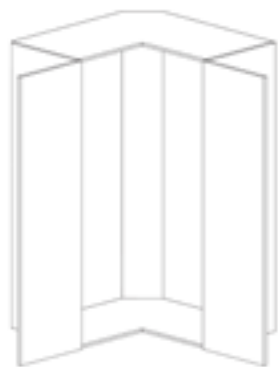

MÓDULO CON PUERTA ABATIBLE

Formado por:
Casco (superior, inferior y trasero)
Costados
2 Puertas

UNIT WITH SWINGING DOOR

Formed by:
frame (upper, lower y back)
sides
2 doors

ANCHURA	CÓDIGO	ALTURA	CÓDIGO
30 - 39 CM	101	HASTA 240 CM	Z
40 - 49 CM	102	DL 241 A 270 CM	W
60 - 69 CM	103		

RAXXX (Z/W)



MÓDULO CON PUERTA CORREDERA

Formado por:
Casco (superior, inferior y trasero)
Costados
2 Puertas

UNIT WITH SLIDING DOOR
Formed by:
frame (upper, lower y back)
sides
2 doors

ANCHURA	CÓDIGO	ALTURA	CÓDIGO
160 - 199 CM	010	Hasta a 240 CM	Z
200 - 240 CM	011	De 241 a 270 CM	W

RBXXX (Z/W)



MÓDULO CON PUERTA CORREDERA

Formado por:
Casco (superior, inferior y trasero)
Costados
3 Puertas

UNIT WITH SLIDING DOOR
Formed by:
frame (upper, lower y back)
sides
3 doors

ANCHURA	CÓDIGO	ALTURA	CÓDIGO
240 - 270 CM	012	Hasta 240 CM	Z
280 - 310 CM	013	De 241 a 270 CM	W
320 - 360 CM	014		

COPLANAR / COPLANARES

PAXXX (Z/W)



MÓDULO CON PUERTA COPLANAR

Formado por:
Casco (superior, inferior y trasero)
Costados
2 Puertas

UNIT WITH COPLANAR DOOR
Formed by:
frame (upper, lower y back)
sides
2 doors

ANCHURA	CÓDIGO	ALTURA	CÓDIGO
160 - 199 CM	010	Hasta 240 CM	Z
200 - 240 CM	011	De 241 a 270 CM	W

MÓDULOS / UNITS

AUTOPORTANTES / SELF SUPPORTING

PF0000



PERFILERÍA ETSECUTIVE
Para módulos de vestidores autoportantes.

ETSECUTIVE PROFILES
For walk-in closet Self supporting units.

SE0000

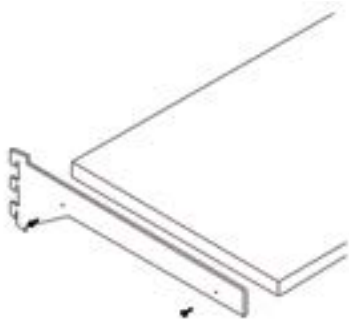

SOPORTE PARA ESTANTES
Para módulos de
vestidores autoportantes.

SHELVES SUPPORT
For walk-in closet Self supporting units.

LAXXX (Z)



LATERAL, DIVISOR INTERIOR.
 Anchura de 60 cm
 SIDE, INTERIOR DIVIDER.
 60 cm width

ALTEURA	CÓDIGO
HASTA 49 CM	001
50 - 99 CM	002
100 - 149 CM	003
150 - 199 CM	004

ESXXX (R/E)

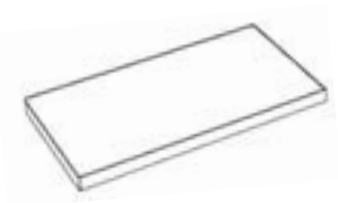

ESTANTE PARA INTERIOR.
 Disponible en recto y esquinero
 INTERIOR SHELVES.
 Available straight and for corner

ANCHURA	CÓDIGO	TIPO
30 - 39 CM	001	RECTO
40 - 49 CM	002	ESQUINERO
50 - 59 CM	003	
60 - 69 CM	004	
70 - 79 CM	005	
80 - 89 CM	006	
90 - 99 CM	007	
100 - 109 CM	008	
110 - 120 CM	009	

ZC0000



ZÓCALO DECORATIVO.
 Según acabado del armario o aluminio.
 Altura de 10 cm
 DECORATIVE PLINTH.
 According to the cabinet finish or aluminium.
 10 cm height

RG000 (Z/W)



REGLETA DECORATIVO.
Según acabado del armario.
Anchura de 15 cm.
FIXED PIECE.
According to the cabinet finish.
10 cm width

AL-TURA	CÓDIGO
HASTA 240 CM	Z
DL 241 a 270 CM	W

RTXXX (Z/W)



REMATE A TECHO.
Según acabado del armario.
CEILING FIXED PIECE.
According to the cabinet finish.

ANCHURA	CÓDIGO	AL-TURA	CÓDIGO
30 - 39 CM	001	HASTA 15 CM	Z
40 - 49 CM	002	DL 16 a 30 CM	W
50 - 59 CM	003		
60 - 69 CM	004		
70 - 79 CM	005		
80 - 89 CM	006		
90 - 99 CM	007		
100 - 109 CM	008		
110 - 120 CM	009		

TRXXX (Z/W)



TRASERA DE ARMARIO
 CABINET BACK

ANCHURA	CÓDIGO
30 - 39 cm	001
40 - 49 cm	002
50 - 59 cm	003
60 - 69 cm	004
70 - 79 cm	005
80 - 89 cm	006
90 - 99 cm	007
100 - 109 cm	008
110 - 120 cm	009

CP0000

CORTE EN PROFUNDIDAD
 DEPTH CUT

CL0000

CORTE EN LONGITUD
 LENGTH CUT

CAJONERAS / DRAWERS

SIMPLES / DRAWERS

CS1XX (T/N)

CON TIRADOR
WITH HANDLE

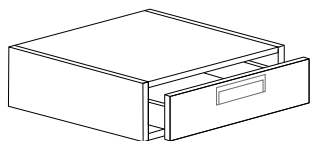

SIN TIRADOR
WITHOUT HANDLE

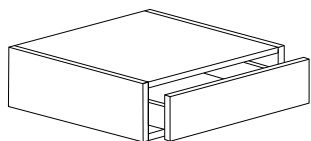

CAJONERA SIMPLE DE UN CAJÓN
20 cm de alto
Con o sin tirador

SIMPLE CHEST OF DRAWERS
WITH ONE DRAWER
20 cm height
With or without handle

ANCHURA	CÓDIGO	TIPO	CÓDIGO
30 - 60 CM	11	CON TIRADOR	T
61 - 90 CM	12	SIN TIRADOR	N
91 - 120 CM	13		

CS1XX (T/N)

CON TIRADOR
WITH HANDLE

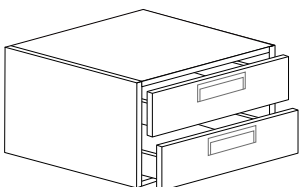

SIN TIRADOR
WITHOUT HANDLE

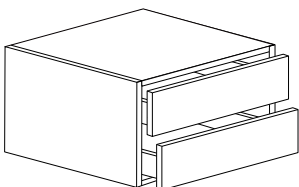

CAJONERA SIMPLE DE DOS CAJONES
40 cm de alto
Con o sin tirador

SIMPLE CHEST OF DRAWERS
WITH TWO DRAWER
40 cm height
With or without handle

ANCHURA	CÓDIGO	TIPO	CÓDIGO
30 - 60 CM	21	CON TIRADOR	T
61 - 90 CM	22	SIN TIRADOR	N
91 - 120 CM	23		

CS1XX (T/N)

CON TIRADOR
WITH HANDLE

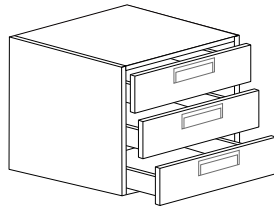

SIN TIRADOR
WITHOUT HANDLE

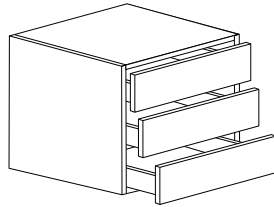

CAJONERA SIMPLE DE TRES
CAJONES
60 cm de alto
Con o sin tirador

SIMPLE CHEST OF DRAWERS
WITH THREE DRAWER
60 cm height
With or without handle

ANCHURA	CODIGO	TIPO	CODIGO
30 - 60 CM	31	CON TIRADOR	T
61 - 90 CM	32	SIN TIRADOR	N
91 - 120 CM	33		

CS1XX (T/N)

CON TIRADOR
WITH HANDLE

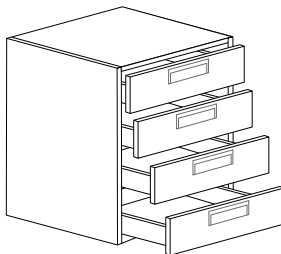

SIN TIRADOR
WITHOUT HANDLE

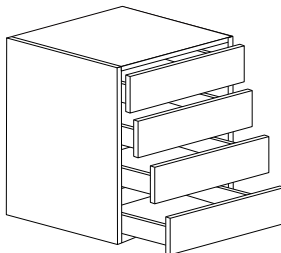

CAJONERA SIMPLE DE CUATRO
CAJONES
80 cm de alto
Con o sin tirador

SIMPLE CHEST OF DRAWERS
WITH FOUR DRAWER
80 cm height
With or without handle

ANCHURA	CODIGO	TIPO	CODIGO
30 - 60 CM	41	CON TIRADOR	T
61 - 90 CM	42	SIN TIRADOR	N
91 - 120 CM	43		

CAJONERAS SIMPLES

CS1XX (T/N)

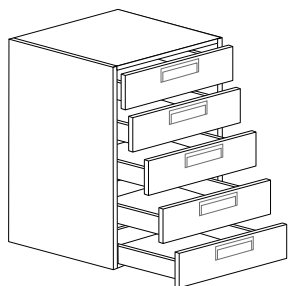

CON TIRADOR
WITH HANDLE

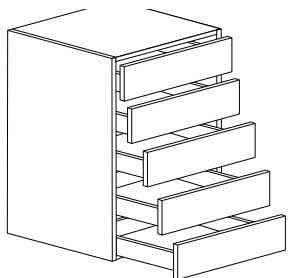

SIN TIRADOR
WITHOUT HANDLE

CAJONERA SIMPLE DE CINCO
CAJONES
100 cm de alto
Con o sin tirador

SIMPLE CHEST OF DRAWERS
WITH FIVE DRAWER
100 cm height
With or without handle

ANCHURA	CÓDIGO	TIPO	CÓDIGO
30 - 60 cm	01	CON TIRADOR	T
61 - 90 cm	02	SIN TIRADOR	N
91 - 120 cm	03		

CD2XX (T/N)

CON TIRADOR
WITH HANDLE

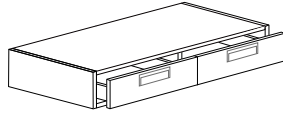

SIN TIRADOR
WITHOUT HANDLE

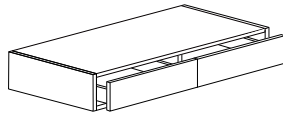

CAJONERA DOBLE DE UN
CAJÓN
20 cm de alto
Con o sin tirador

DOUBLE CHEST OF DRAWERS
WITH ONE DRAWER
20 cm height
With or without handle

ANCHURA	CÓDIGO	TIPO	CÓDIGO
60 - 90 cm	12	CON TIRADOR	T
91 - 120 cm	13	SIN TIRADOR	N

CD2XX (T/N)

CON TIRADOR
WITH HANDLE

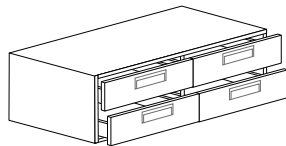

SIN TIRADOR
WITHOUT HANDLE

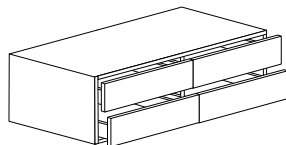

CAJONERA DOBLE DE DOS
CAJONES
40 cm de alto
Con o sin tirador

DOUBLE CHEST OF DRAWERS
WITH TWO DRAWER
40 cm height
With or without handle

ANCHURA	CÓDIGO	TIPO	CÓDIGO
60 - 90 cm	22	CON TIRADOR	T
91 - 120 cm	23	SIN TIRADOR	N

CAJONERAS / DRAWERS

DOBLES / DOUBLE

CD2XX (T/N)

CON TIRADOR
WITH HANDLE

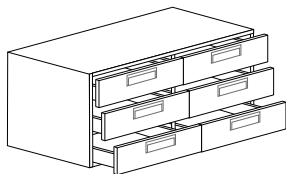

SIN TIRADOR
WITHOUT HANDLE

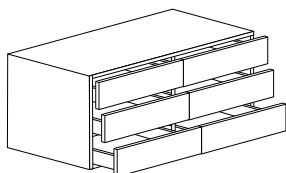

CAJONERA DOBLE DE TRES
CAJONES
60 cm de alto
Con o sin tirador

DOUBLE CHEST OF DRAWERS
WITH THREE DRAWERS
60 cm height
With or without handle

ANCHURA	CÓDIGO	TIPO	CÓDIGO
60 - 90 CM	32	CON TIRADOR	T
91 - 120 CM	33	SIN TIRADOR	N

CD2XX (T/N)

CON TIRADOR
WITH HANDLE

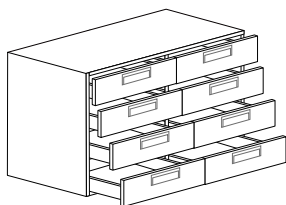

SIN TIRADOR
WITHOUT HANDLE

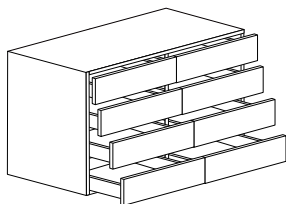

CAJONERA DOBLE DE CUATRO
CAJONES
80 cm de alto
Con o sin tirador

DOUBLE CHEST OF DRAWERS
WITH FOUR DRAWERS
80 cm height
With or without handle

ANCHURA	CÓDIGO	TIPO	CÓDIGO
60 - 90 CM	42	CON TIRADOR	T
91 - 120 CM	43	SIN TIRADOR	N

CD2XX (T/N)

CAJONERA DOBLE DE CINCO
CAJONES
100 cm de alto
Con o sin tirador

ANCHURA	CÓDIGO	TIPO	CÓDIGO
90 - 95 cm	32	CON TIRADOR	T
91 - 120 cm	33	SIN TIRADOR	N

DOUBLE CHEST OF DRAWERS
WITH FIVE DRAWERS
100 cm height
With or without handle

CON TIRADOR
WITH HANDLE

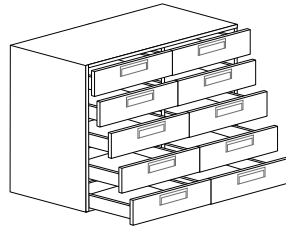

SIN TIRADOR
WITHOUT HANDLE

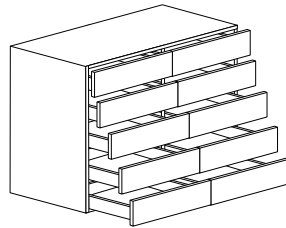

GAVETEROS / BIG DRAWERS

SIMPLES / SIMPLE

GS1XX (T/N)

CON TIRADOR
WITH HANDLE

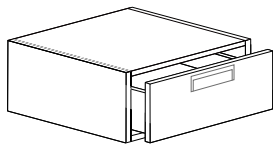

SIN TIRADOR
WITHOUT HANDLE

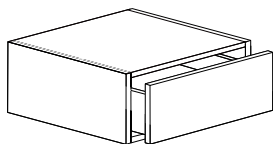

GAVETERO SIMPLE
30 cm de alto
Con o sin tirador

SIMPLE CHEST OF BIG
DRAWERS
30 cm height
With or without handle

ANCHURA	CÓDIGO	TIPO	CÓDIGO
30 - 60 CM	11	CON TIRADOR	T
61 - 90 CM	12	SIN TIRADOR	N
91 - 120 CM	13		

GS1XX (T/N)

CON TIRADOR
WITH HANDLE

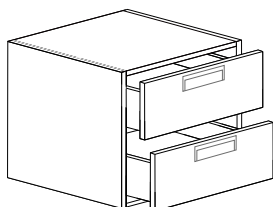

SIN TIRADOR
WITHOUT HANDLE

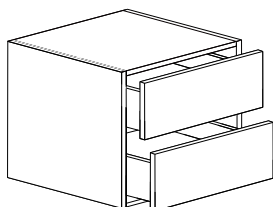

GAVETERO SIMPLE DE DOS
GAVETAS
60 cm de alto
Con o sin tirador

SIMPLE CHEST OF TWO BIG
DRAWERS
60 cm height
With or without handle

ANCHURA	CÓDIGO	TIPO	CÓDIGO
30 - 60 CM	21	CON TIRADOR	T
61 - 90 CM	22	SIN TIRADOR	N
91 - 120 CM	23		

GS1XX (T/N)

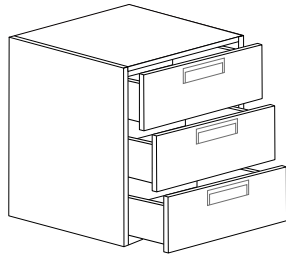

CON TIRADOR
WITH HANDLE

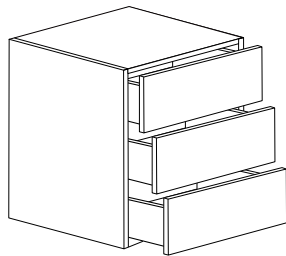

SIN TIRADOR
WITHOUT HANDLE

GAVETERO SIMPLE DE TRES
GAVETAS
90 cm de alto
Con o sin tirador

SIMPLE CHEST OF THREE BIG
DRAWERS
90 cm height
With or without handle

ANCHURA	CODIGO	TIPO	CODIGO
30 - 60 CM	31	CON TIRADOR	T
61 - 90 CM	32	SIN TIRADOR	N
91 - 120 CM	33		

GAVETEROS / BIG DRAWERS

DOBLES / DOUBLE

GD2XX (T/N)

CON TIRADOR
WITH HANDLE

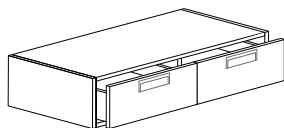

SIN TIRADOR
WITHOUT HANDLE

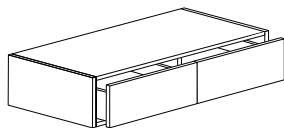

GAVETERO DOBLE
30 cm de alto con dos gavetas
Con o sin tirador

DOUBLE CHEST OF BIG
DRAWERS
30 cm height
With or without handle

ANCHURA	CODIGO	TIPO	CODIGO
60 - 90 CM	12	CON TIRADOR	T
91 - 120 CM	13	SIN TIRADOR	N

GD2XX (T/N)

CON TIRADOR
WITH HANDLE

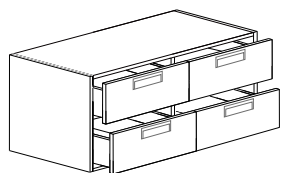

SIN TIRADOR
WITHOUT HANDLE

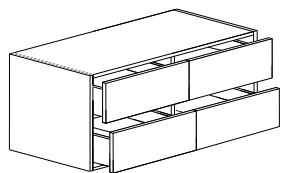

GAVETERO DE DOS GAVETAS
60 cm de alto
Con o sin tirador

DOUBLE CHEST OF TWO BIG
DRAWERS
60 cm height
With or without handle

ANCHURA	CODIGO	TIPO	CODIGO
60 - 90 CM	22	CON TIRADOR	T
91 - 120 CM	23	SIN TIRADOR	N

GAVETERO SIMPLE DE DOS
GAVETAS
60 cm de alto
Con o sin tirador

GD2XX (T/N)

GAVETERO DE TRES GAVETAS
90 cm de alto
Con o sin tirador

ANCHURA	CODIGO	TIPO	CODIGO
60 - 90 cm	32	CON TIRADOR	T
91 - 120 cm	33	SIN TIRADOR	N

DOUBLE CHEST OF THREE BIG
DRAWERS
90 cm height
With or without handle

CON TIRADOR
WITH HANDLE

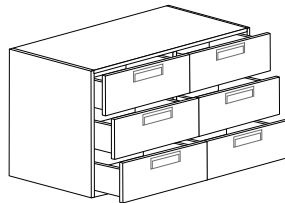

SIN TIRADOR
WITHOUT HANDLE

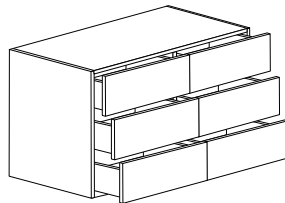

ACCESORIOS / ACCESSORIES

05.1 ACCESORIOS / ACCESSORIES *(P.41)*

BARRA DE COLGAR - BARRA EXTRAÍBLE / HANGER RAIL

BARRA ILUMINACIÓN / LIGHTING HANGER RAIL

ZAPATERO EXTRAÍBLE / PULL-OUT SHOE RACK

PANTALONERO EXTRAÍBLE / PULL-OUT TROUSER RACK

CESTA EXTRAÍBLE / PULL-OUT BASKET

ESTANTE EXTRAÍBLE / PULL-OUT SHELF

CORBATERO - CORBATERO EXTRAÍBLE / TIE RACK

ACCESORIOS / ACCESSORIES

PR0000



PANTALONERO EXTRAÍBLE CON 12 BARRAS.
Ancho de 340 mm y fondo de 480 mm
PULL-OUT TROUSER RACK WITH 12 HANGER.
340 mm width and 480 mm depth

ELXXXX



PANTALONERO EXTRAÍBLE CON 12 BARRAS.
Alto de 888 mm y fondo de 271 mm
PULL-OUT TROUSER RACK WITH 12 HANGERS.
888 mm height and 271 mm depth

	ANCHO	LARGO
560	1070 mm	888 mm
770	1700 mm	888 mm

PEXXXX



PANTALONERO EXTRAÍBLE.
Incluye bandeja para accesorios. Fondo 500 mm
PULL-OUT TROUSER RACK.
Accessory track included. 500 mm depth

CE0000



CORBATERO EXTRAÍBLE.
Capacidad para 12 corbatas.
Fondo de 345 mm
PULL-OUT TIE RACK
For 12 ties. 345 mm depth

	ANCHO	LARGO
60	65 cm	500 mm
70	75 cm	500 mm
80	85 cm	500 mm
90	95 cm	500 mm

ZPXXXX



ZAPATERO EXTRAÍBLE PANELABLE
PULL-OUT SHOERACK

BB0000



BARRA DE BISUTERÍA / BOLSOS.
Capacidad para 15 productos de bisutería.
Fondo de 345 mm
JEWELRY HANGER / BAGS HANGER
For 15 products. 345 mm depth

	ANCHO	CAPACIDAD ZAPATOS	LARGO
60	60 cm	4	500 mm
70	70 cm	6	500 mm
80	80 cm	7	500 mm
90	90 cm	8	500 mm

CXXXXX



CESTA EXTRAÍBLE.
Alto de 175 mm y fondo de 497 mm.
PULL-OUT BASKET.
175 mm height and 497 mm depth.

BEXXXX



BARRA DE COLGAR EXTRAÍBLE
PULL-OUT HANGER RAIL

ANCHO		LARGO
40	CM	5510
45	CM	5520
50	CM	5530

EE0000



ESTANTE EXTRAÍBLE.
Anchura del estante según armario
PULL-OUT SHELF.
Width according to the wardrobe's width

ANCHURA		LARGO
50	55 CM	551
40	45 CM	552
50	55 CM	553
60	65 CM	554
70	75 CM	555
80	85 CM	556
90	95 CM	557
100	105 CM	558
110	120 CM	559

BIXXXX



BARRA CON ILUMINACIÓN
LIGHTING HANGER RAIL

LARGITUD		LARGO
46	56 CM	551
57	76 CM	552
77	96 CM	553
97	115 CM	554

CC0000

CARGADOR TOMA DE CORRIENTE
con cable USB de 5 m
POWER OUTLET CHARGER
With 5 m USB cable

